

LIST OF KIT ELEMENTS

LOVA Set

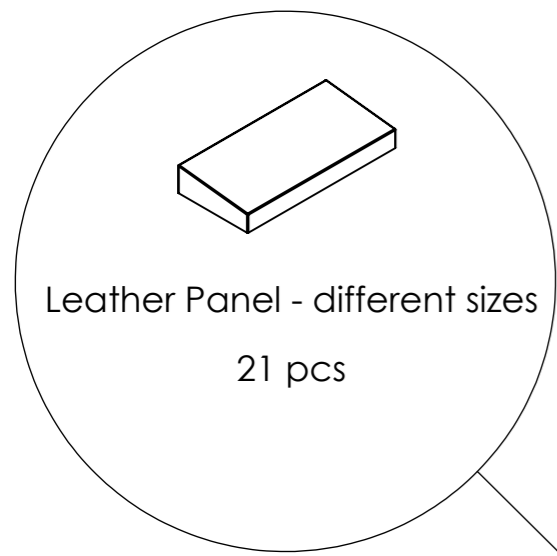

Leather Panel - different sizes
21 pcs

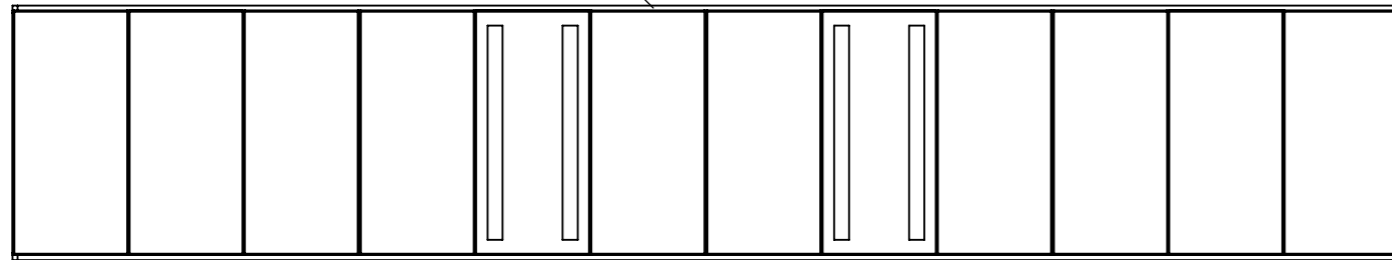

Metal Shelf of the Stand
1 pc

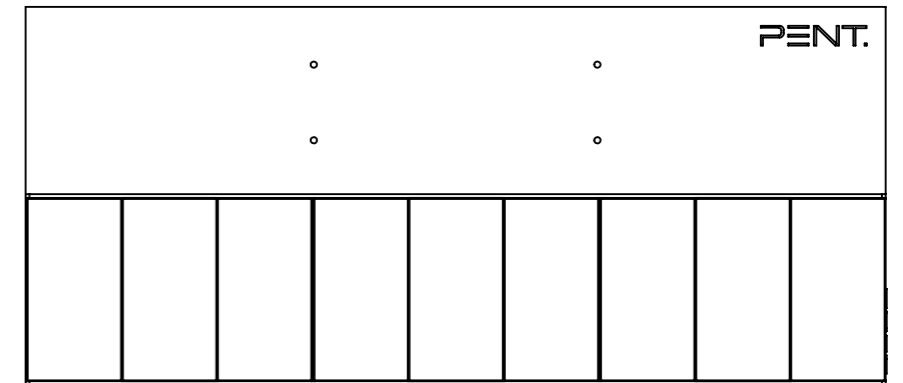

Base of the Stand with Bottom Metal Shelf
1 pc

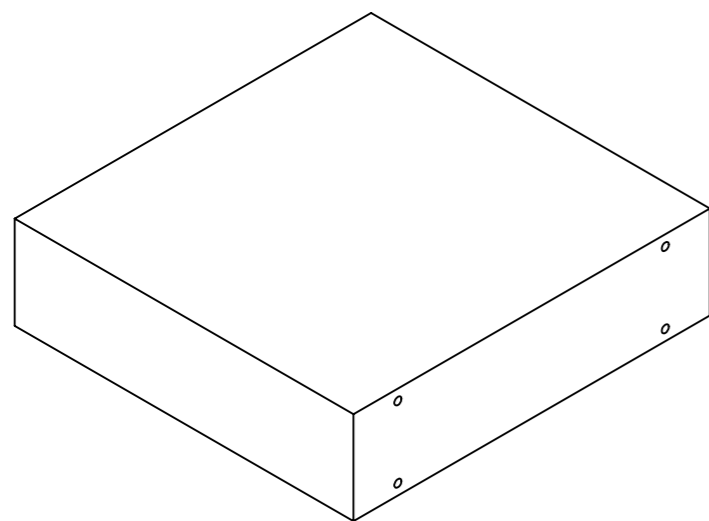

Leg of the Stand
1 pc



Countersunk Head Screw
M6x50 - 4 pcs
M6x25 - 4 pcs

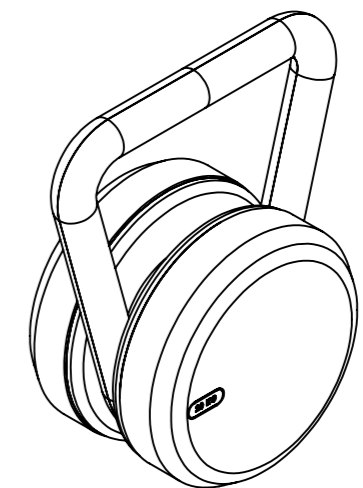

Kettlebells
4 kg, 6 kg, 8 kg, 10 kg, 12 kg, 16 kg, 20 kg
one each

STEP 1

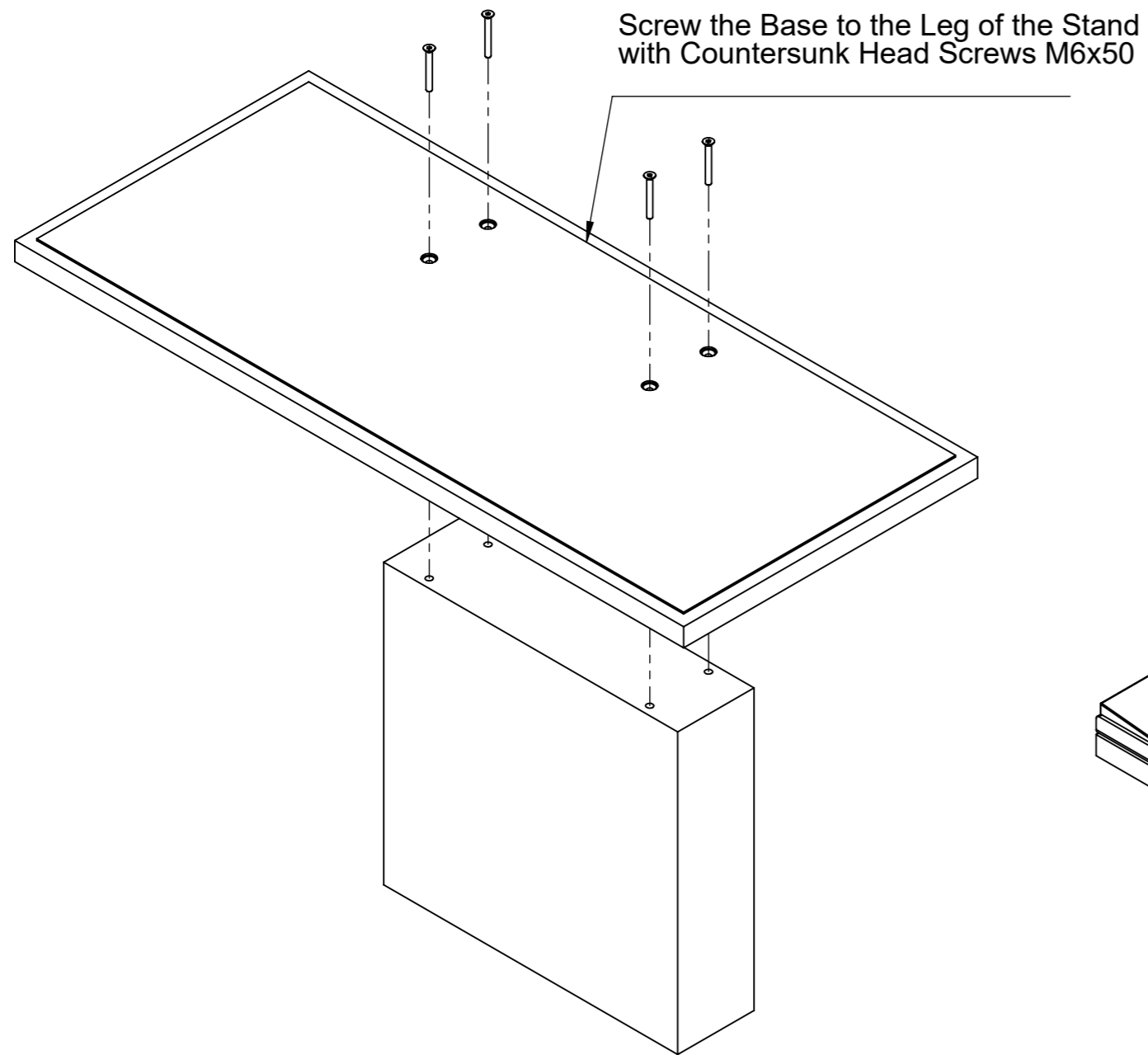

STEP 2

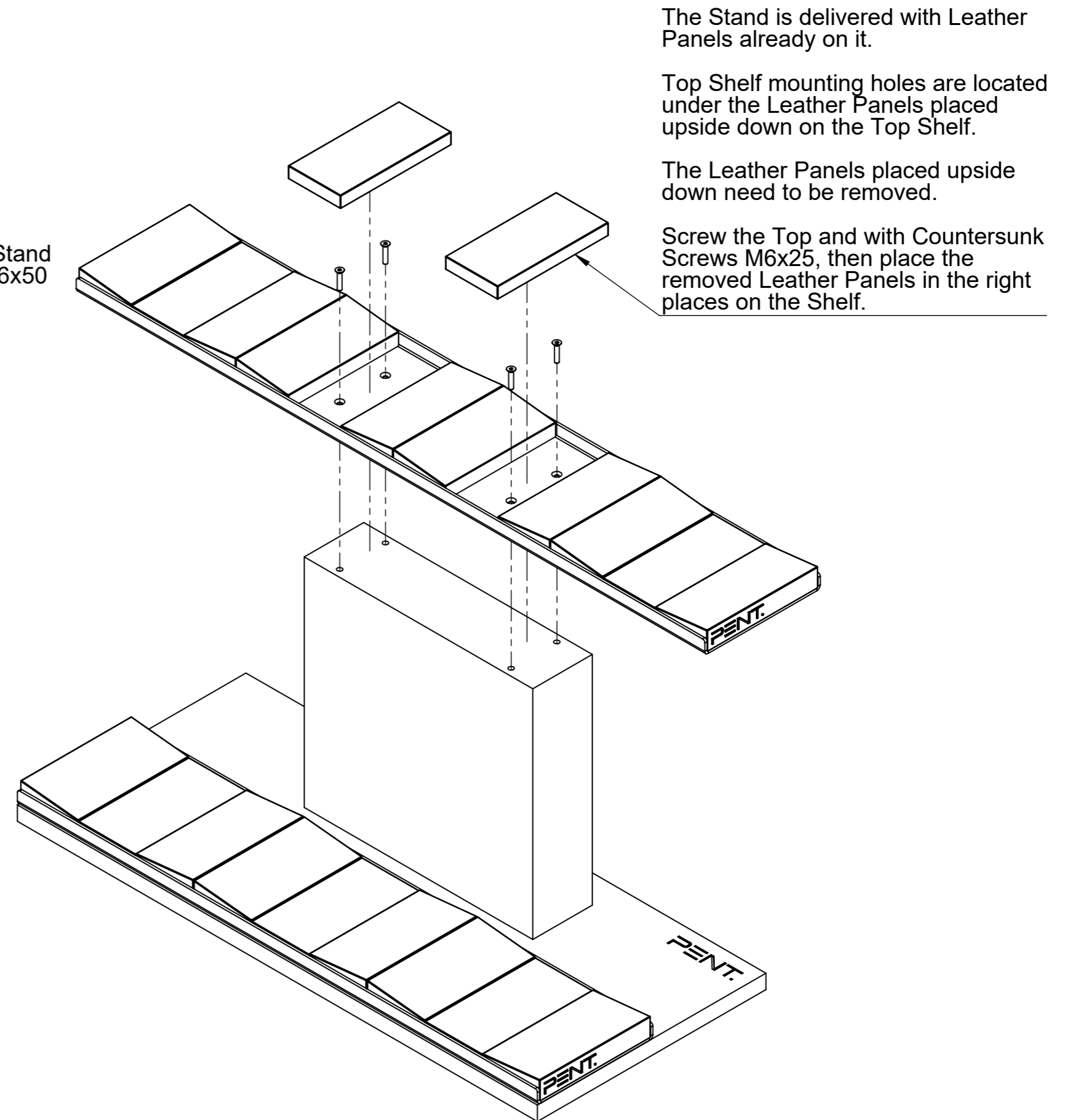

STEP 3

Place the Kettlebells on the Leather Panels.
Place the Kettlebells from the lightest on the Top Stand Shelf, to the heaviest on the Bottom Stand Shelf

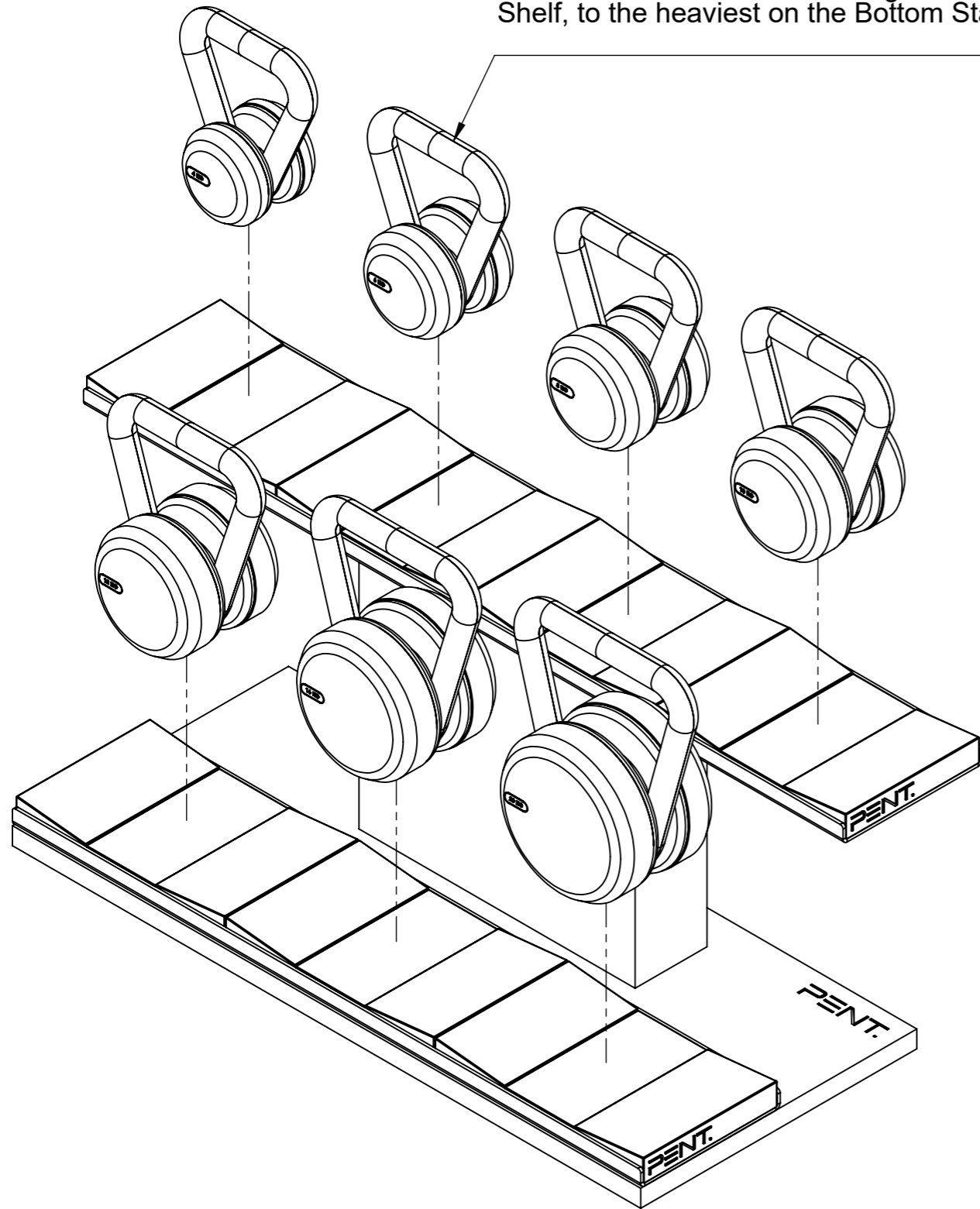

FINISHED ASSEMBLY

