

LIST OF KIT ELEMENTS

MOXA Power

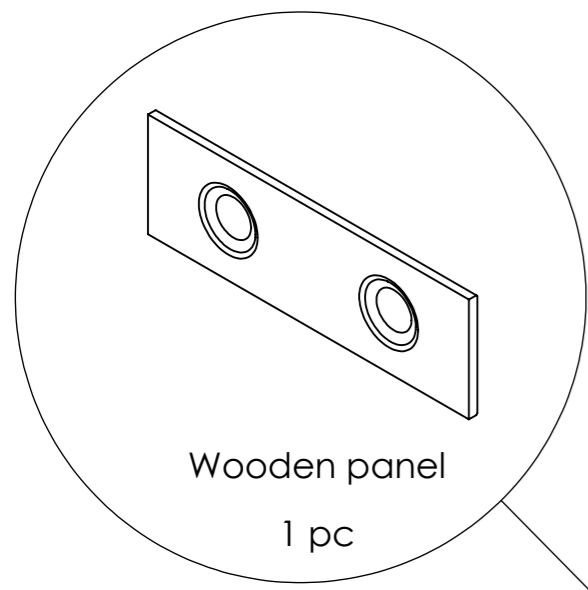

Wooden panel
1 pc

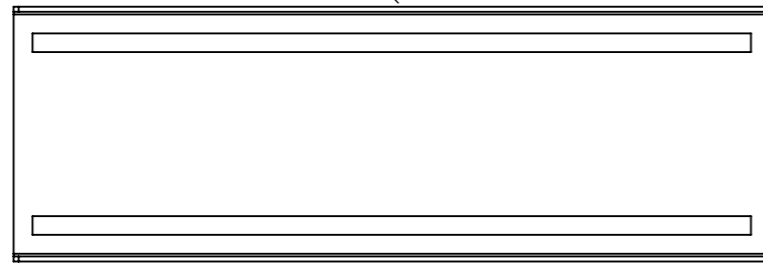

Metal Shelf of the Stand
1 pc

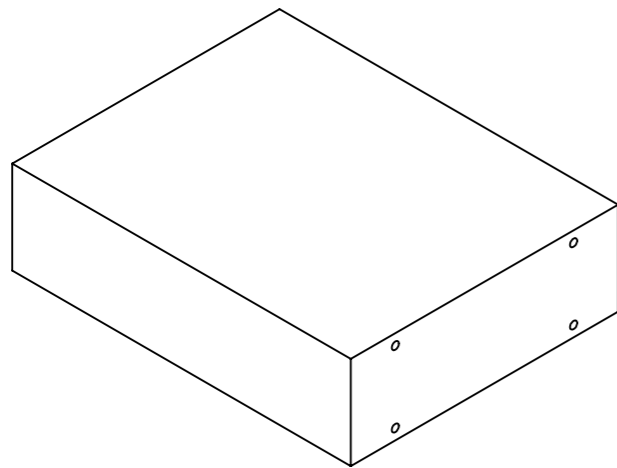

Leg of the Stand
1 pc



Countersunk Head Screw
M6x50 - 4 pcs
M6x25 - 4 pcs

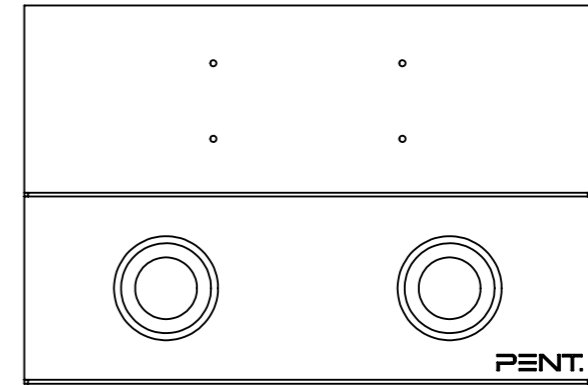

Base of the Stand with Bottom Metal Shelf
1 pc

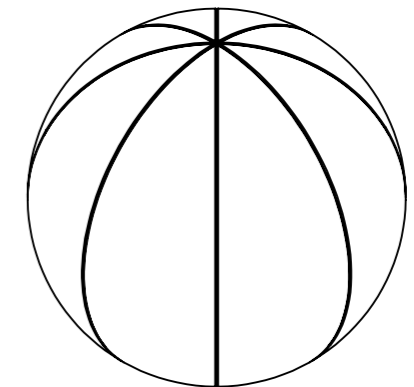

Weight Ball
12 kg, 16 kg, 20 kg, 24 kg
one each

STEP 1

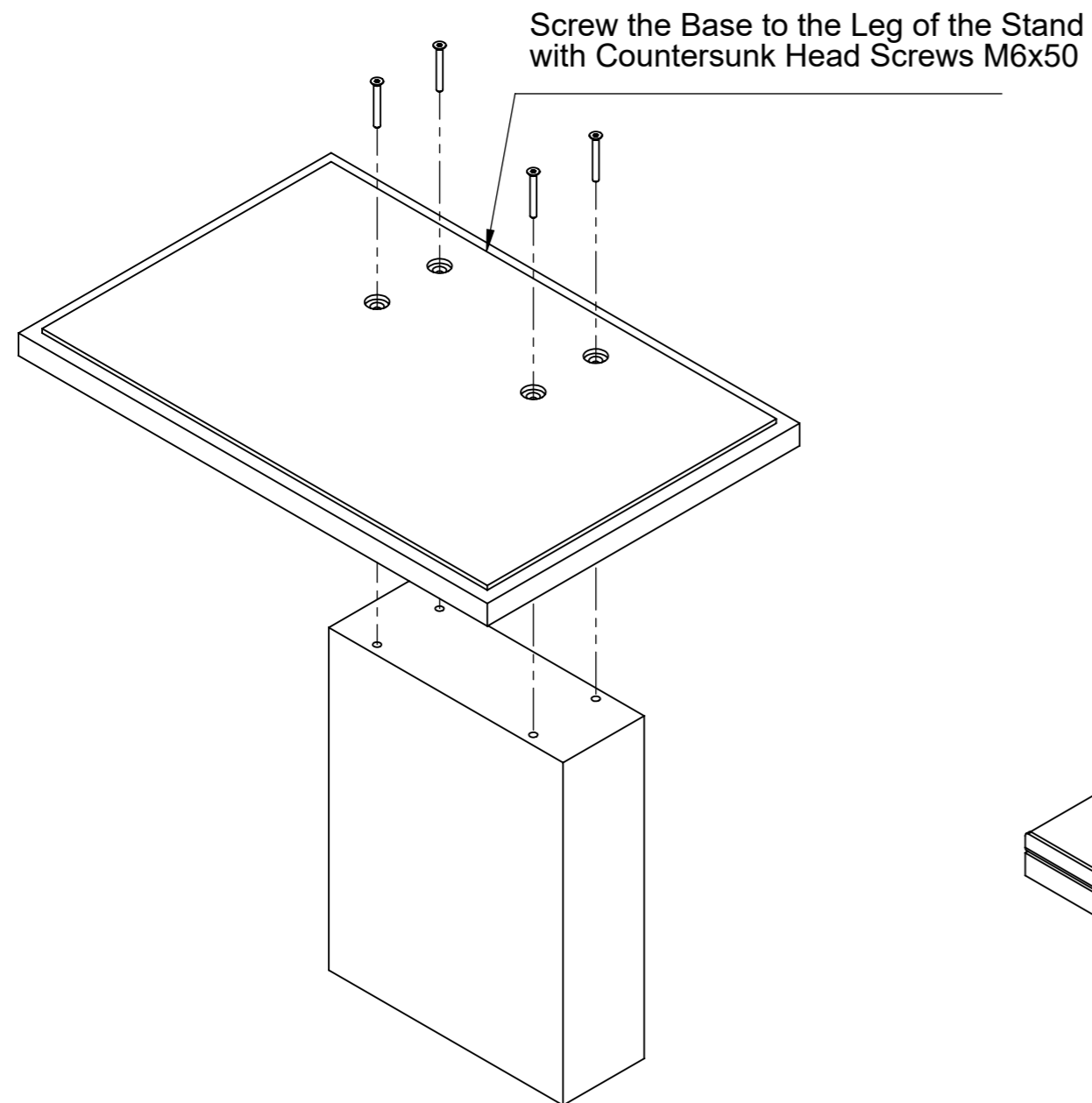

STEP 2

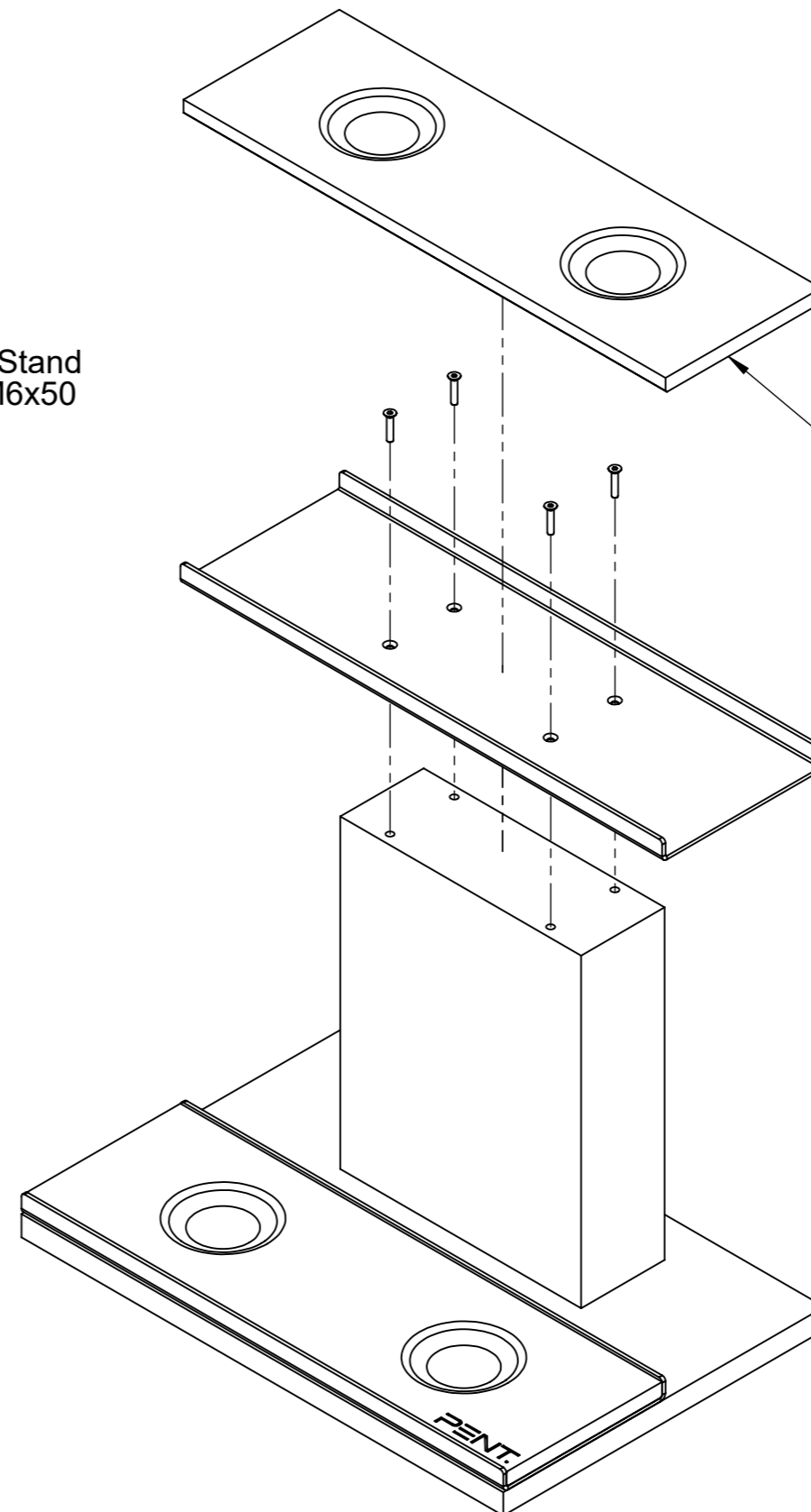

The Stand is delivered with Wooden Panels already on it.

Top Shelf mounting holes are located under the Wooden Panel placed upside down on the Top Shelf.

The Wooden Panel placed upside down need to be removed. Screw the Top Shelf with Countersunk Screws M6x30, then place the removed Wooden Panel on the Top Stand Shelf.

STEP 3

Place the Weight Balls on
Wooden Panels.
Place the Weight Balls from the
lightest on the Top Stand Shelf,
to the heaviest on the Bottom
Stand Shelf

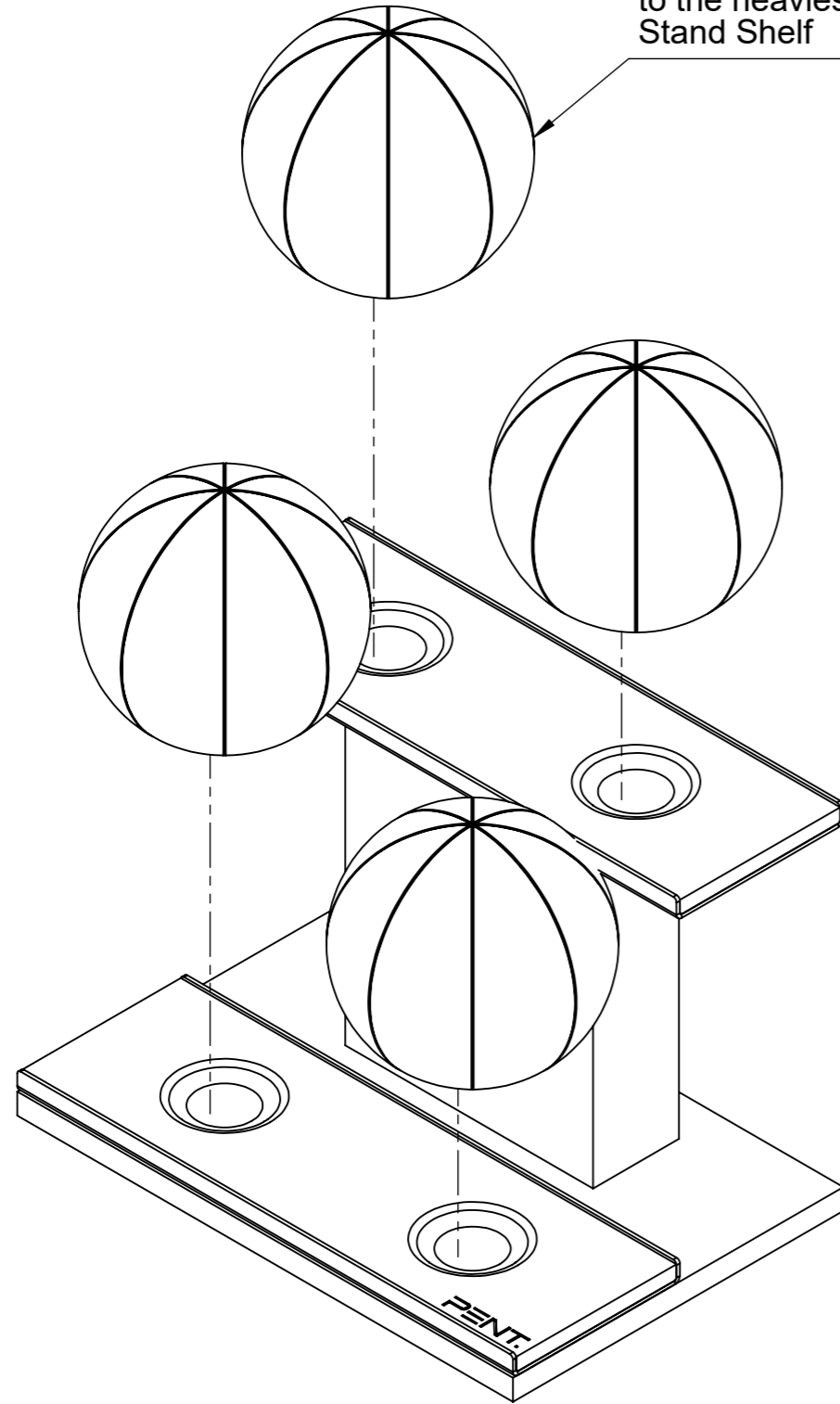

FINISHED ASSEMBLY

